

SONY®

Component/OEM

Communication Color Video Cameras

EVI-D70 & EVI-D70P

EVI-D70/W & EVI-D70P/W



FEATURES

Sony's New Pan/Tilt/Zoom Remote Camera - Captures Every Scene

Sony continues to add choice and flexibility to its industry-leading pan/tilt/zoom camera lineup with the introduction of the Sony EVI-D70, EVI-D70P, EVI-D70W and EVI-D70P/W color video cameras. These four EVI models combine a high-quality color video camera with the flexibility of remote pan/tilt/zoom operation, all in a compact easy-to-use package.

In addition, this powerful P/T/Z camera now is available in two housing colors; select either a black (EVI-D70 and EVI-D70P) or white (EVI-D70W and EVI-D70P/W) housing to best suit your application.

Incorporating an 18x optical zoom lens, these cameras allow a user to zoom in on a small or distant object with exceptional clarity. Compared to their predecessor, the EVI-D30/D31, these cameras offer a wider pan/tilt range, and a faster pan/tilt mechanism. Above all, these cameras are ceiling mountable - a first for Sony's popular EVI cameras.

These EVI models are also equipped with a variety of convenient features such as an Auto ICR function, Alarm function and RS-232C/422 serial control, making them ideal for any remote-shooting applications such as distance learning, places of worship, courtrooms, event venues, concert halls, and more.



216x Zoom Ratio (18x Optical, 12x Digital)

Wide-Range, High-Speed Pan/Tilt

- Pan angle: -170° to +170°
(max. pan speed: 100°/s)
- Tilt angle: -30° to +90°
(max. tilt speed: 90°/s)

Superb Picture Quality With EXview HAD CCD™

- Minimum illumination: 1 lx
- Horizontal resolution:
 - 470 TV lines (EVI-D70 and EVI-D70W)
 - 460 TV lines (EVI-D70P and EVI-D70P/W)

Ceiling-Mount or Desktop Installation

RS-232C or RS-422 Serial Control (VISCA™ Command)

Auto ICR Function

Alarm Function

Auto Power-Off/Night Power-Off Function

Daisy Chain Capability (Up to seven cameras)

Six-Position Preset

Multi-Function IR Remote Commander® Unit

EVI-D30/D31 Emulation Mode

37mm Mount for Optional Wide Conversion Lens



Superb Picture Quality with EXview HAD CCD

The adoption of Sony EXview HAD CCD technology improves basic camera performance. For example, these cameras offer superb sensitivity of 1 lx (typical), and a low smear level and D-range. (see Fig. 1)

RS-232C or RS-422 Serial Control (VISCA Command)

All camera settings and pan/tilt/zoom functions can be controlled remotely via a PC. With the RS-232C connection, maximum cable length can be extended to 15 m (50 feet), while the RS-422 connection extends this further to 1200 m (4000 feet).

Auto ICR (IR Cut filter Removal) Function Fig. 2

The Auto ICR function automatically switches the settings to attach or remove the IR Cut filter for increased sensitivity. With a set level of darkness, the IR Cut filter is automatically disabled (ICR ON), and the infrared sensitivity is increased. With a set level of brightness, the filter is automatically enabled (ICR OFF). The ICR automatically engages depending on the ambient light, allowing the cameras to be effective both in day and night environments.

Alarm Function and AE Spot Setting

These cameras provide an alarm function that can detect changes within a user-designated area of an image.* When a change in AF, AE or both is detected, these cameras output an alarm trigger signal to the external equipment via the VISCA protocol. In combination with the Spot AE function, these cameras also detect changes in the luminance level, and they output an alarm signal. The detecting area can be applied to any of 16 vertical and 16 horizontal blocks. (see Fig. 3)

*Using any of the pan/tilt/zoom functions will disable the alarm.



Rear Panel

IR sensitivity



EVI-D70/D70P (1 lx)
EVI-D70/W / EVI-D70P/W



Conventional Cameras (3 lx)

Smear



EVI-D70/D70P
EVI-D70/W / EVI-D70P/W

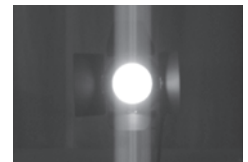

Conventional Cameras

Fig. 1 Comparison: IR Sensitivity and Smear

When auto slow shutter is on

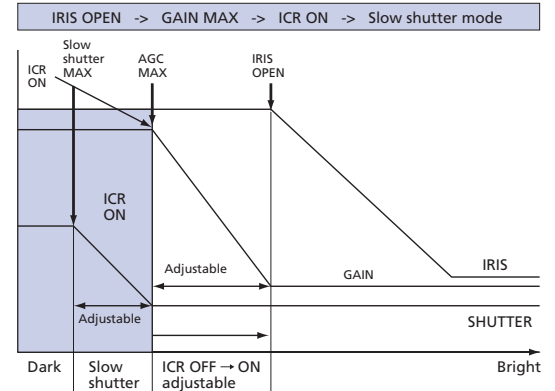

Fig. 2 Auto ICR

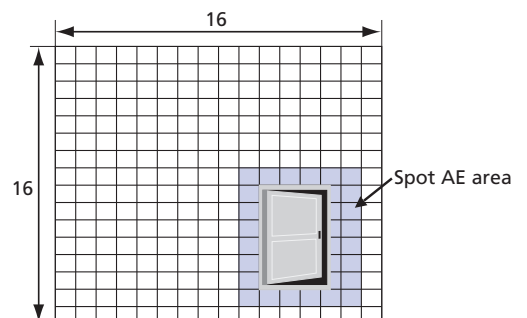

Fig. 3 AE Spot Setting

SPECIFICATIONS

	EVI-D70 & EVI-D70/W	EVI-D70P & EVI-D70P/W
Signal system	NTSC	PAL
Image sensor	1/4-type EXview HAD CCD	
Number of effective pixels (H x V)	768 x 494	752 x 582
Horizontal resolution	470 TV lines (wide end)	460 TV lines (wide end)
Lens	18x zoom, f=4.1 mm (wide) to 73.8 mm (tele), F1.4 to F3.0	
Horizontal angle of view	2.7° (tele end) to 48° (wide end)	
Minimum object distance	10 mm (wide end), 800 mm (tele end)	
Minimum illumination	1 lx (F1.4)	
Auto exposure	Auto/Manual/Priority AE, Exposure compensation, Back-light compensation	
Shutter speed	1 to 1/10,000 s	
Gain	Auto/Manual (-3 to +28 dB, 2 dB steps)	
White balance	Auto/ATW/Indoor/Outdoor/One push/Manual	
S/N ratio	More than 50 dB	
Pan/tilt	Pan: ±170° (Max. speed: 100°/s), Tilt: -30° to +90° (Max. speed: 90°/s)	
Position preset	6 positions	
Picture effect	Neg. Art, Black & White	
Video output	VBS, Y/C	
Control terminal	RS-232C (8-pin mini DIN) control (VISCA)/RS-422 (9-pin) control (VISCA), baud rate: 9.6 Kb/s, 38.4 Kb/s	
Power requirement	DC 10.8 to 13.2 V	
Power consumption	12 W	
Operating temperature	32 to 40 °F (0 to 40 °C)	
Storage temperature	-4 to +140 °F (-20 to +60 °C)	
Dimensions (W x H x D)	5 1/4 x 5 3/4 x 5 3/4 inches (132 x 144 x 144 mm)	
Weight	2 lb 2 oz (950 g)	
Body color	Black, White	
Supplied accessories	AC adaptor, IR remote commander unit, Ceiling bracket, Operating instructions	
Optional accessories	RM-BR300 remote controller with joystick*	

*Not all functions are supported. See www.sony.com/videocameras for additional information.

DIMENSIONS

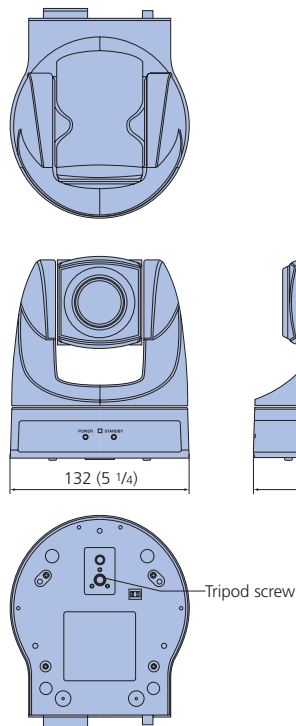

PAN/TILT RANGE

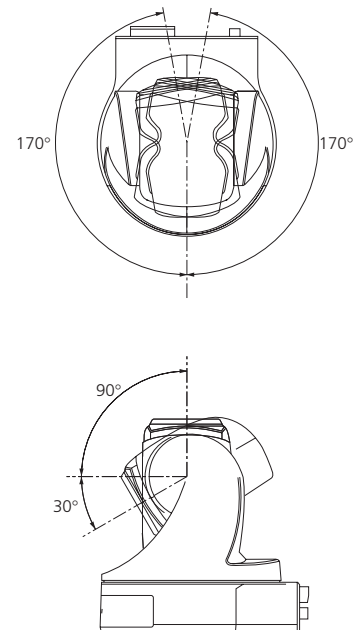

SONY®

Sony Electronics Inc.
1 Sony Drive
Park Ridge, NJ 07656
www.sony.com/videocameras

IS-1174-A
MK10053V2IW04FEB

©2004 Sony Corporation. All rights reserved.
Reproduction in whole or in part without written permission is prohibited.
Design, features, and specifications are subject to change without notice.
All non-metric weights and measurements are approximate.
Sony, EXview HAD CCD, VISCA and Remote Commander are trademarks of Sony Corporation.

image is
everything™

Printed in USA (4/04)